

POLYETHYLENE CONTAINERS INC

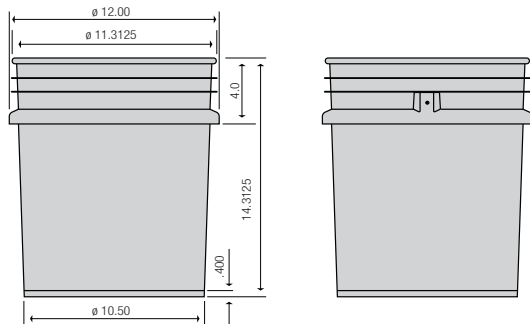

FEATURES

- 5-Gallon Container
- Polyethylene Containers pails are manufactured using high quality 100% recyclable HDPE resin
- Standard colors: white, black, natural, grey, red, blue, yellow, orange, green
- Custom Colors: available to meet your packaging needs
- Decoration: 4 color dry offset printing/Heat Transfer Labeling
- Lid Options: flexible pour spout, flexible pour spout with vent, tint plug, or plain cover
- Food contact approved high density polyethylene material
- Gasket: EPDM (Ethylene Propylene Diene (M-class) Rubber)
- Plastic Finger Grip Handle



Wall Thickness	MM	Inch
----------------	----	------

Pails 1.78 .070

Gasket Lid 2.03 .090

Standard Weight (+/- 2%)	G	Lb.
--------------------------	---	-----

Pail (with handle) 771 1.70

Gasket Lid 282 0.62

Thermal Resistance (tested with water)

Filling From -18°C (0°F) to 66°C (150°F)

Warehousing From -18°C (0°F) to 39°C (102°F)

Top Loading Resistance

60kg (132lb) at 23°C (73°F) *30 day test

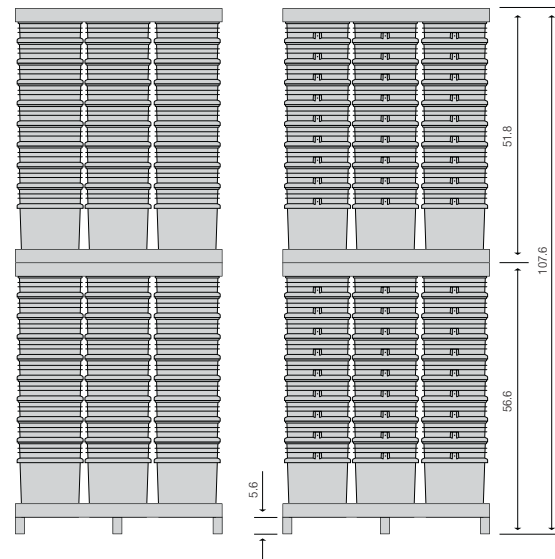

Item	Pkg	Pack Size	Per Floor Space (fs)	53' Trailer fs/ftl qty
Pails	Tray	120	240	28 = 6720
Lids	Tray	600	1200	5 2/3 = 6720
Lids	Tray	240	1200	5 2/3 = 6720